



TESTING

FITOTERM °C
FITOCLIMA °C H₂O



TEMPERATURE / HUMIDITY CONTROL

'WALK-IN' ENVIRONMENTAL CHAMBERS FOR CLIMATE AND TEMPERATURE TESTING





FitoTerm & FitoClima temperature and humidity testing chambers offer highly precise and reproducible conditions for climatic and temperature testing in many industries. **Common applications include:**

Environmental Testing

Electronics, Automotive, Aerospace, Building materials, Military equipment, Materials in general

Research

Quality Control

Production facilities



ARALAB

ARALAB is a company specialized in designing, developing, manufacturing and servicing of high quality Climatic Chambers.

For more than 25 years we have been perfecting ways to create and control temperature, humidity and many other environmental conditions that respond to the needs of customers all around the world.

Only the highest quality components are used to manufacture our chambers so customers can have the best equipment for their research and testing purposes.

Aralab chambers.
Your own climate.



Aralab is ISO:9001 certified for Quality Management

FEATURES

The most advanced technology in climatic control

Internal aerodynamic optimization to ensure uniformity of climatic conditions

Time saving features with easily configurable testing programs that can run, start and stop automatically

Highly resistant stainless steel interior for maximum durability and easy cleaning

Able to comply with the most demanding testing standards and customer specifications

Nonpolluting construction and cooling system

Compliant with international standards and requirements EN, IEC, DIN, ISO, NP and UNE

TEMPERATURE AND HUMIDITY CONTROL

FITOTERM Chambers – Temperature control only

FITOTERM CHAMBERS	TEMPERATURE RANGE	HUMIDITY RANGE
FitoTerm E20	-20°C to +150°C	N/A
FitoTerm E40	-40°C to +150°C	N/A
FitoTerm E60	-60°C to +150°C	N/A

FITOCLIMA Chambers – Temperature and Humidity control

FITOCLIMA CHAMBERS	TEMPERATURE RANGE	HUMIDITY RANGE
FitoClima EP, EC & ECP 20	-20°C to +150°C	10 to 95% RH
FitoClima EP, EC & ECP 40	-40°C to +150°C	10 to 95% RH
FitoClima EP, EC & ECP 60	-60°C to +150°C	10 to 95% RH

Note: EP, EC & ECP refer to the humidity sensors. EP = Electronic Psychrometric; EC = Electronic Capacitive; ECP = Electronic Capacitive + Psychrometric



OTHER TECHNICAL CHARACTERISTICS

FITOCLIMA / FITOTERM CHAMBERS	
HEATING SPEED *	From 1,5°C to 5°C / minute
COOLING SPEED *	From 1°C to 5°C / minute Depending on model and compressor(s) power. Temperature change rates can be adjusted to fit customer requirements.
TEMPERATURE PRECISION	± 0,5°C
TEMPERATURE FLUCTUATION	± 1,0°C
TEMPERATURE UNIFORMITY	± 1,0°C
HUMIDITY RANGE ** (FITOCLIMA MODELS ONLY)	10% to 95% RH (* ** HUMIDITY CONTROL POSSIBLE IN CLIMATIC RANGE OF 10°C TO 95°C)
HUMIDITY PRECISION	± 1 % RH
HUMIDITY FLUCTUATION	± 2 % RH
HUMIDITY UNIFORMITY	± 2 % RH

* Standard heating and cooling speeds will vary with the climatic/temperature ranges. Please inform Aralab about the application or testing standard so we can provide with the most adequate solution. Aralab Testing chambers are configured and factory calibrated to comply with the necessary heating / cooling speed requirements

DIMENSIONS AND DRAWINGS

FITOTERM / FITOCLIMA 8.000

	EXTERIOR DIMENSIONS (H x W x D) (mm)	2.400 x 2.300 x 4.000
	INTERIOR DIMENSIONS (H x W x D) (mm)	1.980 x 2.000 x 1.990

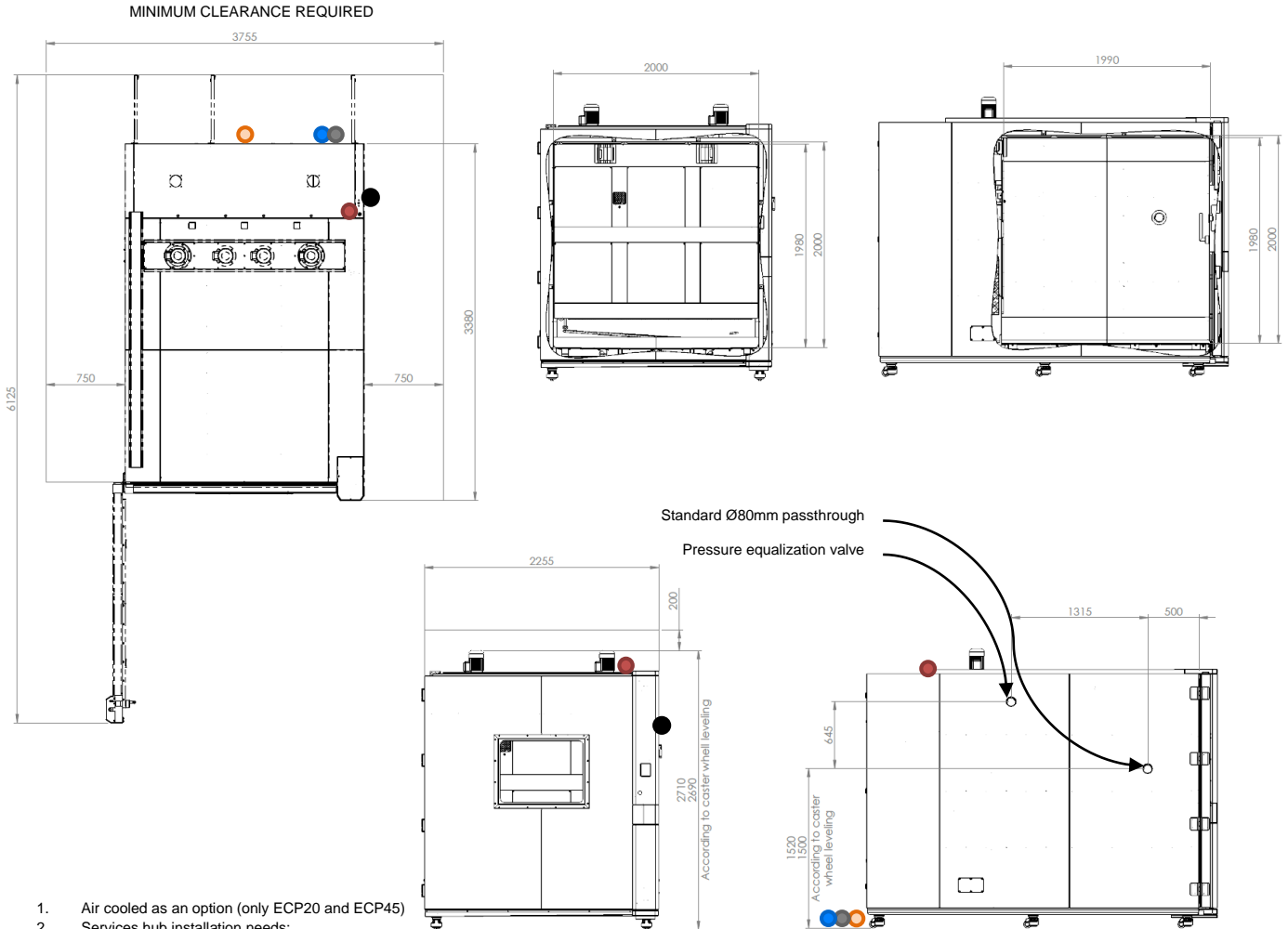

1. Air cooled as an option (only ECP20 and ECP45)
2. Services hub installation needs:
 - ½" demineralized water supply
 - 50mm water drain at floor level
3. Electrical cabinet installation needs:
 - Supply power ECP20:
400VAC, 50Hz, 55A / 3-Phase + Neutral + Ground
Electrical protection: Circuit breaker 3 x 63A + N with 300mA differential
Single Phase electrical cable RV-K 5G16 on the top
 - Supply power ECP45:
400VAC, 50Hz, 80A / 3-Phase + Neutral + Ground
Electrical protection: Circuit breaker 3 x 80A + N with 300mA differential
3-Phase electrical cable RV-K 3x25 + 2G16 on the top
 - Supply power ECP60:
400VAC, 50Hz, 125A / 3-Phase + Neutral + Ground
Electrical protection: Circuit breaker 3 x 125A + N with 300mA differential
3-Phase electrical cable RV-K 3x50 + 2G35 on the top
4. Standard water cooled:
 - Water flow (at 25 °C): up to 5000 litres/hour (for -45 °C models)
up to 10000 litres/hour (for -60 °C models)
 - Intake pressure: 2 to 5 bar
 - Water entry and exit pipe: 1" or 28mm
 - Differential pressure between entry and exit: ≥ 2,5 bars
 - Maximum temperature of water entry: 26 °C
 - Minimum temperature of water entry: 16 °C
 - Recommended temperature of water entry: 18 °C

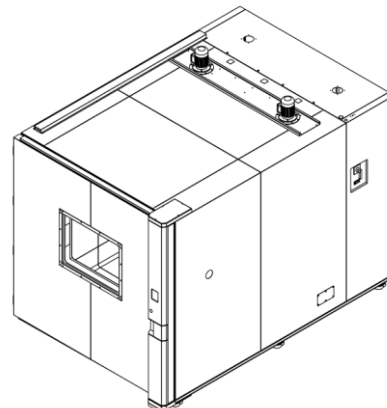

FITOTERM / FITOCLIMA 12.000

	EXTERIOR DIMENSIONS (H x W x D) (mm)	2.400 x 2.300 x 4.000
	INTERIOR DIMENSIONS (H x W x D) (mm)	1.980 x 2.000 x 3.000

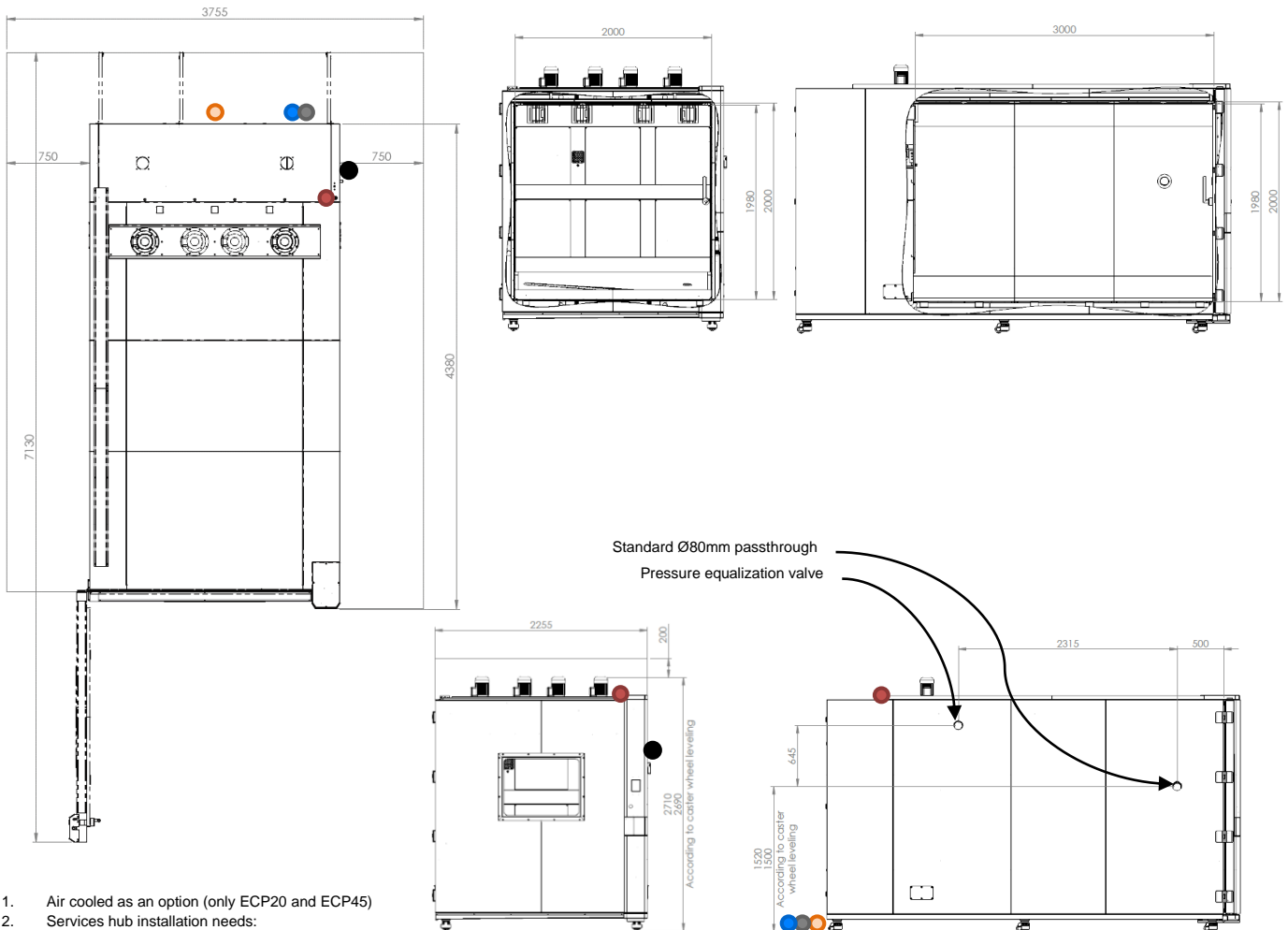
MINIMUM CLEARANCE REQUIRED

- Air cooled as an option (only ECP20 and ECP45)
- Services hub installation needs:
 - ½" demineralized water supply
 - 50mm water drain at floor level
- Electrical cabinet installation needs:
 - Supply power ECP20:
400VAC, 50Hz, 55A / 3-Phase + Neutral + Ground
Electrical protection: Circuit breaker 3 x 63A + N with 300mA differential
Single Phase electrical cable RV-K 5G16 on the top
 - Supply power ECP45:
400VAC, 50Hz, 80A / 3-Phase + Neutral + Ground
Electrical protection: Circuit breaker 3 x 80A + N with 300mA differential
3-Phase electrical cable RV-K 3x25 + 2G16 on the top
 - Supply power ECP60:
400VAC, 50Hz, 125A / 3-Phase + Neutral + Ground
Electrical protection: Circuit breaker 3 x 125A + N with 300mA differential
3-Phase electrical cable RV-K 3x50 + 2G35 on the top
 - RJ45 Ethernet socket communication port
- Standard water cooled:
 - Water flow (at 25 °C): up to 5000 litres/hour (for -45 °C models)
up to 10000 litres/hour (for -60 °C models)
 - Intake pressure: 2 to 5 bar
 - Water entry and exit pipe: 1" or 28mm
 - Differential pressure between entry and exit: ≥ 2,5 bars
 - Maximum temperature of water entry: 26 °C
 - Minimum temperature of water entry: 16 °C
 - Recommended temperature of water entry: 18 °C

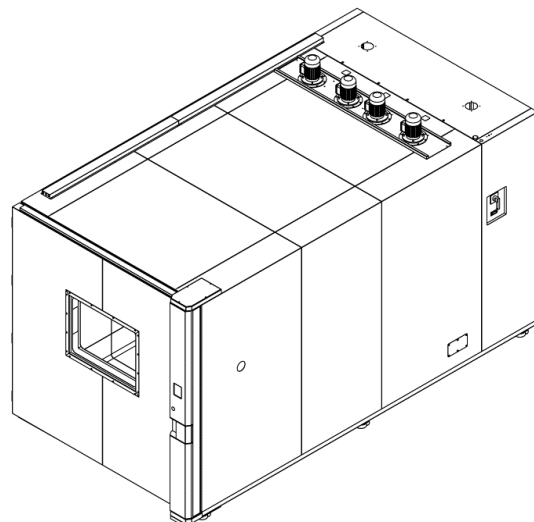

EQUIPMENT DESCRIPTION

Temperature

Control of temperature is made by the ClimaPlus touch-screen controller, high tech temperature and humidity control, developed by Aralab.

Temperature Precision (in the interior of the chamber, at 5 cm from walls, floor and top)

In Time $\leq \pm 0,5^{\circ}\text{C}$
 In Space $\leq \pm 1,0^{\circ}\text{C}$

Temperature Sensors

One (1) PT 100 Class A, located in air treatment tunnel



Heating

By tubular stainless steel electric heaters located in the air treatment tunnel

Cooling

By airtight mechanical compressor group Copeland Scroll (low noise, high efficiency) with enforced ventilation and without use of CFC's.

In -60°C models water cooled condenser is used as standard. As an option the system can be cooled by an air condenser.



Thermal security

Safety thermostats with High / Low temperature configuration, with automatic stop of all heating systems. High / Low temperature alarms programmed in the controller, with mute function. This function won't stop the chamber and it's only used to record the occurrence and to call the attention of the users with an audible alarm.



Humidity (FitoClima models)

Control of humidity is made by the ClimaPlus touch-screen controller, high tech temperature and humidity control, developed by Aralab.

Humidity Precision (in the interior of the chamber, at 5 cm from walls, floor and top)

In Time $\leq \pm 1,0\%$ RH

In Space $\leq \pm 2,0\%$ RH

Humidity Sensors

To measure and control humidity Aralab has different sensor technologies: Psychrometric, Capacitive, or both. Consult Aralab for technical support on the appropriate selection.



Humidity sensors: Humidity Vs. Temperature ranges graphic

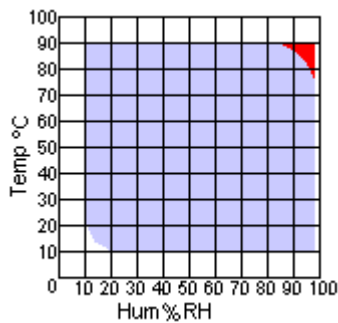

In case of doubt please consult Aralab for help on the choice between Psychrometric or Capacitive humidity sensors.

Humidity / Drying

Humidity: Through thermostatic bath with dew point control.

Drying: Through thermostatic bath with dew point control and additional dry coil

Security

Automatic stop function in case of water failure, with indication on the controller; High / Low Temperature alarms; High / Low humidity alarms;

Air Flow / Ventilation

Air Flow: Forced through 2 blowers installed at the back wall / top of the chamber.

Air Renovation: By lateral port, also for compensating pressure.



Construction

Interior: AISI 304 hermetical welded, vapor tight, stainless steel

Exterior: Zinc mild steel with epoxy coating finish (color RAL 7035)

Insulation: Rock Wool

Interior illumination: Halogen lamp 12V (only available with optional window)

Door: Double silicone joints and anti-condensation heating frames. Automatic electric locks with emergency opening from the inside



Cut-off panel, Security and Communications

Mounted on left lateral panel of the chamber and equipped with:

- High / Low safety thermostat
- Mains Switch
- Audible alarms
- RS232 Output

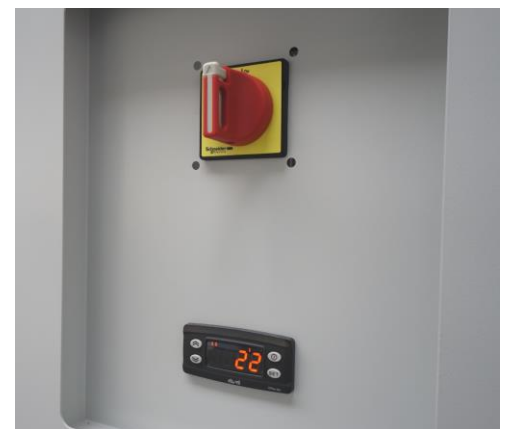

CONTROLLER

CLIMAPLUS V

- Programmable PLC exclusively developed for ARALAB chambers
- Programmable easy to use controller with Touch Screen Display (168 x 112mm)
- Resolution of 0.1°C for Temperature and 0.1% for Relative Humidity
- High performance temperature and humidity control with value correction possibility in all ranges

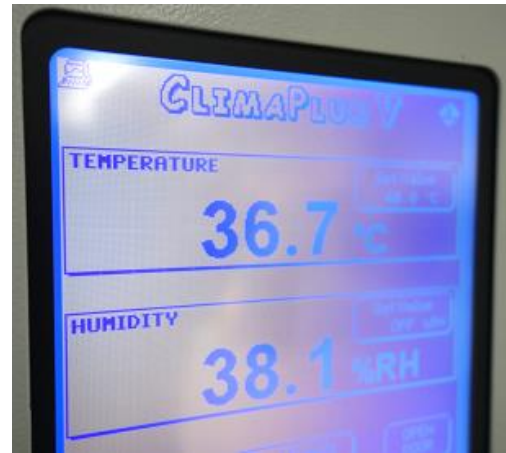

- Capability for creating 50 programs of 50 segments each
- Non-volatile memory
- Automatic restart of tests due to power failure, without losing data and restarting test where it was interrupted

- Real-time monitoring of all functions and control of equipment.
- Send all control settings and system software via RS232 to plant.
- Possibility of programming a delay of the beginning of test
- Monitoring and recording of all alarms
- Possibility of performing events by external commands
- Several outputs for connecting computers or other devices
- Alarms management
- Graphic representation of the tests ran
- Graphical visualization of the test in the controller.
- Possibility of running computer test programs and export them to the controller

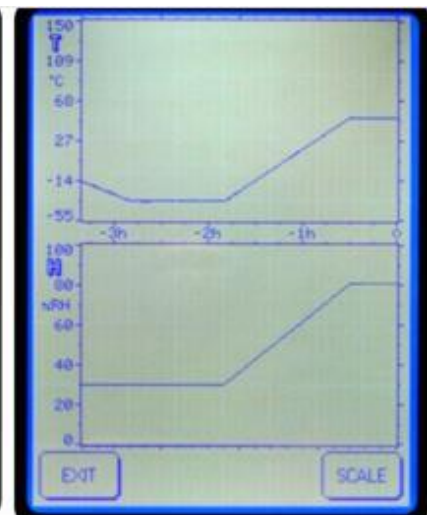

FITOLOG SOFTWARE

The FitoLog software pack is a set of applications designed to facilitate the managing, monitoring and recording of programs and data from the FitoClima chambers. It consists of 3 applications: **FitoLog**, **FitoLogView** and **FitoProgram**.

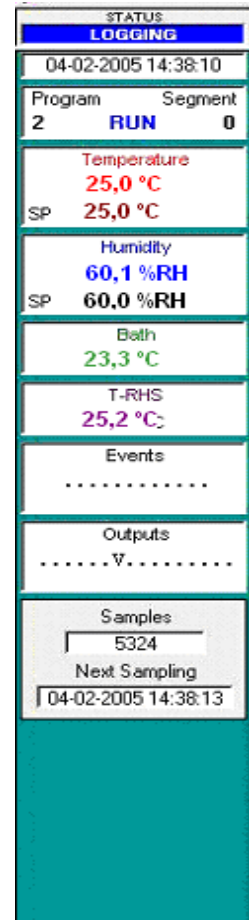
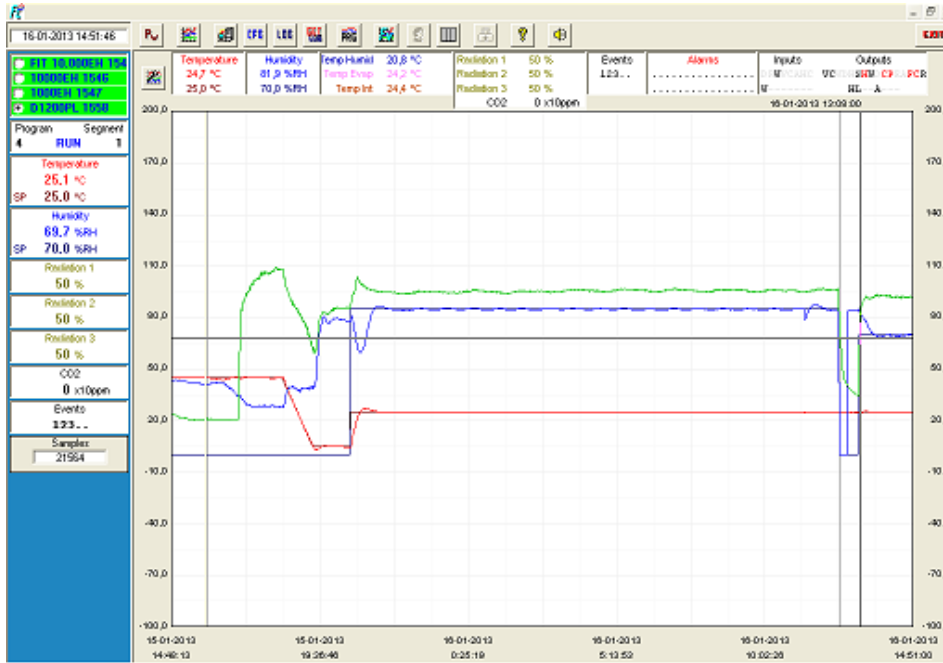

FitoLog: Records and displays in real time all data and details related to the set-points, running variables and equipment behavior. It also retrieves information about the active components of the chamber, running processes, errors, alarms and allows the configuration of periodic or alarm triggered remote notifications (by email or SMS, depending on existing connections and accessories).

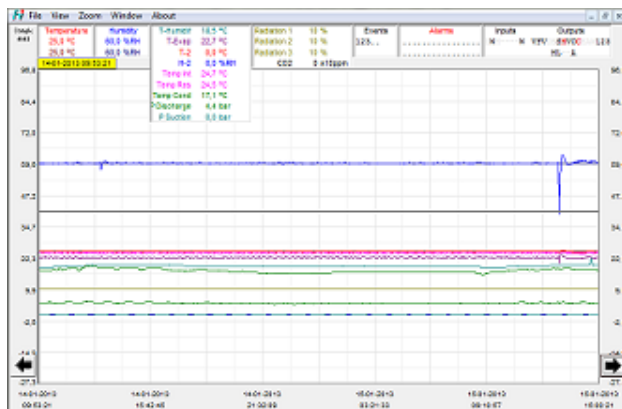

FitoLogView: It is a working tool to process the data recorded by the FitoLog program. One can view, print and export the log contents to other file types, and analyse the data in other data management software (Excel, Star Office, Access or others).

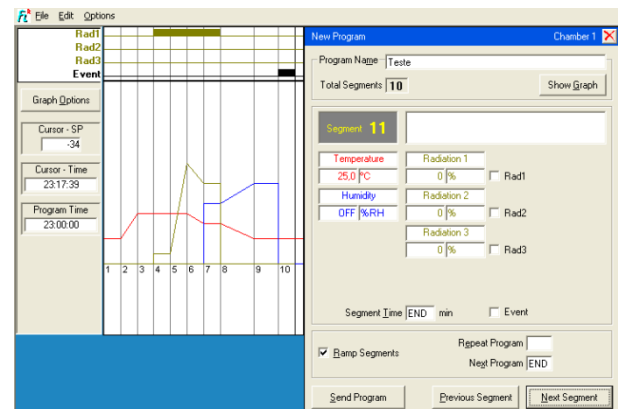

FitoProgram: This application simplifies the creation of programs and its integration on the chamber ClimaPlus controller. Up to 32 programs, each with 24 segments, can be designed and linked to create detailed environmental profiles and simulations.

Notifications, fast diagnostics and prompt troubleshooting: With **FitoLog** it is possible to gather data from each of the chambers systems, which makes it a very useful tool to diagnose any necessary maintenance. This tool works as the “black box” of the equipment, giving Aralab technicians the necessary data to remotely carry out a fast and efficient diagnostic. All that is needed is a FitoLog file.

MOST COMMON OPTIONAL ACCESSORIES

- FitoLog software pack
- Wireless and Ethernet connections for PC running FitoLog software
- Observational anti condensation windows in multi layered glass
- Water demineralizer (for FitoClima Chambers)
- Water conductivity monitor (for FitoClima Chambers)
- Additional entry ports
- Temperature and Humidity calibration certificate from accredited external laboratory
- ISO 17025 calibrations
- Faster heating / cooling temperature change rates
- Shaker/Slip table integration for climatic and vibration testing

Other accessories are available on request. Please consult Aralab.

Window Option

The observation window is composed of a multilayered glass with optimum levels of thermal insulation. The interior and exterior glasses have a heating system that is activated in cold cycles and damp heat to prevent condensation at the surface.

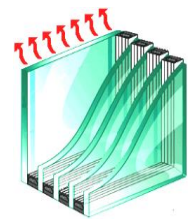

FitoClima 8.000 with observation window on the door



Interior view of FitoClima 8.000 with lateral observation window

Inclusions

- 1 lateral left panel entry port with Ø 80 mm
- Instructions manual in English (other languages upon request)
- 2 years warranty

INSTALLATION REQUIREMENTS

To ensure a correct functioning of the chamber, the following installation conditions are required:

Installation site

The place should be easily accessible, according to equipment dimensions and weight. It should have good air circulation and a room temperature between 10° and 26°C. The floor should be leveled and a minimum distance of 50cm from the walls and other equipment must be kept.

Electrical supply

Near the equipment with the specified requirements: 3/N/PE AC 400V 10%; 50Hz. Amperage will vary with specific requirements of temperature / humidity ranges as well as cooling and heating speeds.

Humidification circuit and demineralized water (for FitoClima models)

The humidification circuit works exclusively with distilled or demineralized water. For this circuit, a water admission pressure of 1 to 6 bares and conductivity of $\leq 5\mu$ Siemens is required.

Water circuit for cooling condenser (optionally, air condenser)

A cold water circuit is required for the cold system condenser. Technical characteristics:

- o Water flow (at 25 °C): up to 5.000 liters/hour for -45°C models and 10.000 liters/hour for -60 °C models
- o Intake pressure: 2 to 5 bar
- o Water entry and exit pipe: 1" or 28mm
- o Differential pressure between entry and exit: > 2,5 bars
- o Maximum temperature of water entry: 26°C
- o Minimum temperature of water entry: 16°C
- o Recommended temperature of water entry: 18°C

Drain

At floor level and near the equipment. The draining of the humidification and cooling systems water is done by gravity. For a correct draining there should be a minimum inclination of 10° in a descending trajectory from the chambers draining pipe until the sewage system.

Features and specifications are subject to change. Aralab continuously studies ways to further develop its products to achieve better performances and overall product quality. As a result, characteristics and specifications provided in this document may be subject to changes.